

900

SERIES

918H



AGCO ALLIS

This manual covers the following Manufacturer's Numbers:

18 HP Tractor: Mfg. No. 1692144

42" Mower: Mfg. No. 1691220

48" Mower: Mfg. No. 1691221

Contents

SAFETY RULES	2	Mower Installation	24
SAFETY DECALS	4	Mower Removal	27
OPERATION	6	Servicing the Mower Blades	28
Controls	6	TROUBLESHOOTING	30
Safety Interlock System	8	Troubleshooting Chart	30
Operation on Slopes	9	Battery Replacement	34
Checks Before Starting	9	Jump Starting with Auxiliary Battery	34
Starting and Stopping	10	Drive Belt Replacement	36
Clutch/Brake Pedal Operation	11	Mower Belt Replacement	37
Mowing Pattern & Tips	11	ADJUSTMENTS	38
Pushing Tractor By Hand	12	Mower Leveling	38
NORMAL CARE	13	Seal Adjustment	40
Normal Care Schedule	13	PTO Clutch Adjustment	41
Storage	14	Mower Belt Stopping Time	41
Lubricate Tractor	14	Parking Brake Adjustment	42
Lubricate Mower	16	Clutch/Brake Pedal Adjustment	42
Check Bevel Gear Box Fluid	17	Neutral Adjustment	44
Check Tire Pressure	18	COMMON REPLACEMENT PARTS	45
Battery Maintenance	18	SPECIFICATIONS	46
Repack Front Wheel Bearings	19	OPTIONAL ATTACHMENTS & ACCESSORIES	48
Check Transmission Fluid Level	20	PARTS MANUAL AVAILABLE	49
Change Transmission Fluid & Filter	21		
Change Engine Oil	23		

NOTE

In this manual, "left" and "right" are referred to as seen from the operating position.

Operation

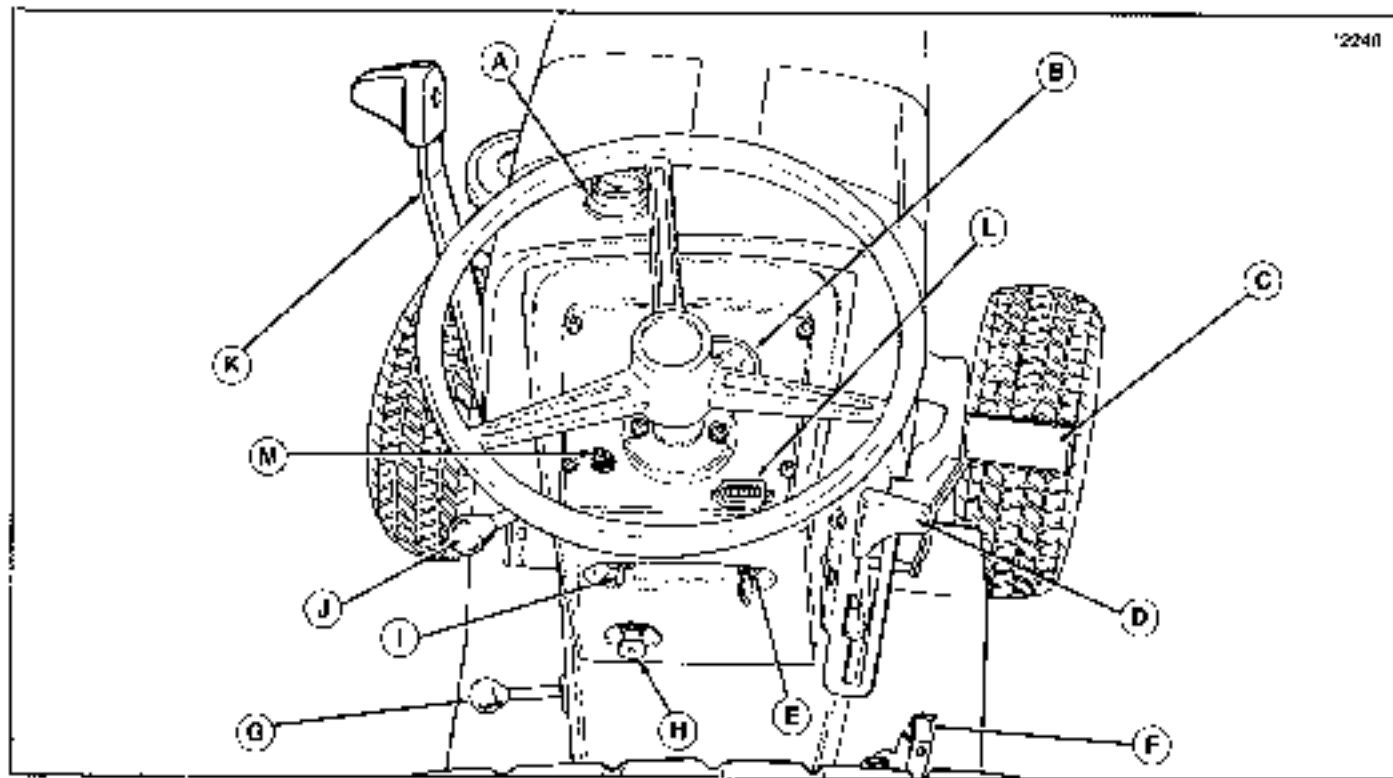

Figure 1. Controls

ITEM	NAME	FUNCTION
A	Gasoline Gauge	Shows gasoline level and serves as tank cap.
B	Ammeter	Shows when battery is being charged or discharged.
C	Clutch/Brake Pedal	Disengages clutch when depressed at least halfway. Applies brake when depressed fully.
D	Transmission Control Lever	Control tractor speed and direction of travel (forward or reverse)
E	Ignition Switch	Operates with key to start, run or stop engine.
F	Parking Brake Lever	Locks brakes to hold tractor in parked position.
G	PTO Lever	Engages and disengages power to attachments.
H	Choke Knob	When pulled out, closes engine choke for cold weather starting.
I	Light Switch	Switches headlights on or off.
J	Engine Speed Control	Controls engine speed.
K	Hydraulic Lift	Lifts attachments to transport position.
L	Hourmeter	Optional accessory to record number of hours engine has run.
M	Spout Rotator	Optional accessory used to rotate spout on 36" and 42" snowthrowers.

PUSHING TRACTOR BY HAND

To push the tractor by hand, the transmission release lever (A, figure 4) must be engaged (pushed all the way down).

To drive tractor, the release lever must be pulled up in the "drive" position. Refer to figure 4.

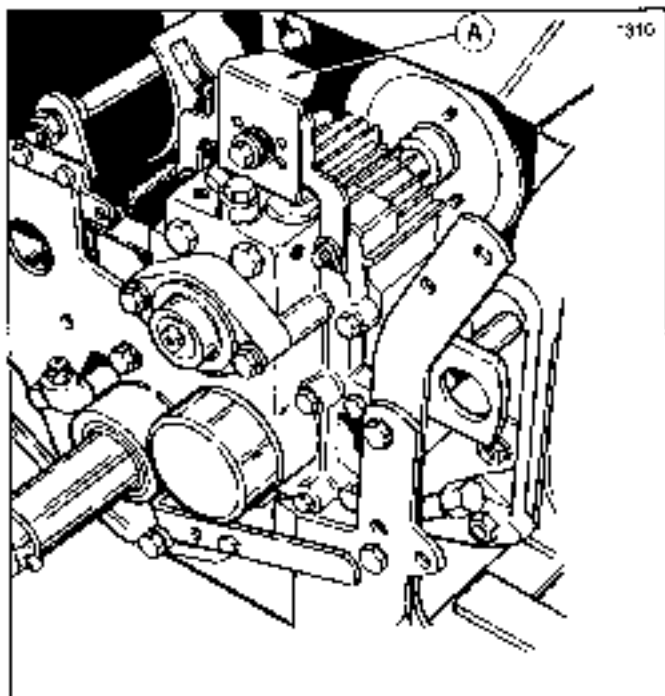

Figure 4.
A. Transmission Release Lever

Normal Care

	See	Before First Use	Before Each Use	Every 5 Hours	Every 25 Hours	Every 100 Hours	Spring & Fall
Safety Items							
Check safety interlock system.	pg. 6	•					•
Check tractor brakes.	pg. 11	•					•
Check mower belt stopping time.	pg. 41	•	After adjustment or service of PTO clutch.				•
Normal Care Items							
Check tractor & mower for loose nuts, screws, bolts, oil leaks, etc.		•	•	•			
Check engine oil level	Eng.Mn	•	•	•			
Check engine & air filter.	" "				••		•••
Change engine oil and filter.*	" "				•••		••••
Lubricate tractor & mower.	pg. 18				•••		
Check fluid levels & tire pressure	pg. 22	•	•		••		
Check transmission fluid.	pg. 23	•		•			•
Change transmission fluid		Every 400 hrs. or for transaxle service only					
Clean battery & cables.	pg. 22					•	
Clean/sharpen blades	pg. 27					•	
Inspect spark plug(s)	Eng.Mn					•	
<p>*Change original engine oil after first 5 hours of operation</p> <p>**More often in hot (over 85° F, 30° C) weather or dusty operating conditions.</p> <p>***Only if tractor is used in both summer (over 40° F, 4.5° C) and winter (under 40° F, 4.5° C). Use SAE 5W-30 engine oil for cold weather operation (under 32° F).</p>							

Normal Care Schedule

Normal Care

LUBRICATE MOWER

1. Remove mower from tractor.
2. Remove cotter pins to fold back the adjusting rods (42" mower) or lift the bail assembly (48" mower).
3. Remove the taprite screws to remove the right hand cover (both covers can be removed to check/clean inside of mower deck.) See figure B.
4. Apply a few drops of oil or one or two shots of grease (if equipped with grease filling) to idler pulley pivot fitting and wipe off excess oil or grease. Do not get oil or grease on mower belt. Idler pulley pivot should be lubricated yearly.
5. Reinstall cover and taprite screws. Be sure the ball fits inside of the ball guide which is located on bottom of cover.
6. Reinstall adjusting rods or bail assembly and secure with cotter pins. Be sure to spread legs of cotter pins.
7. Lubricate the mower arbor as shown in figure BA.

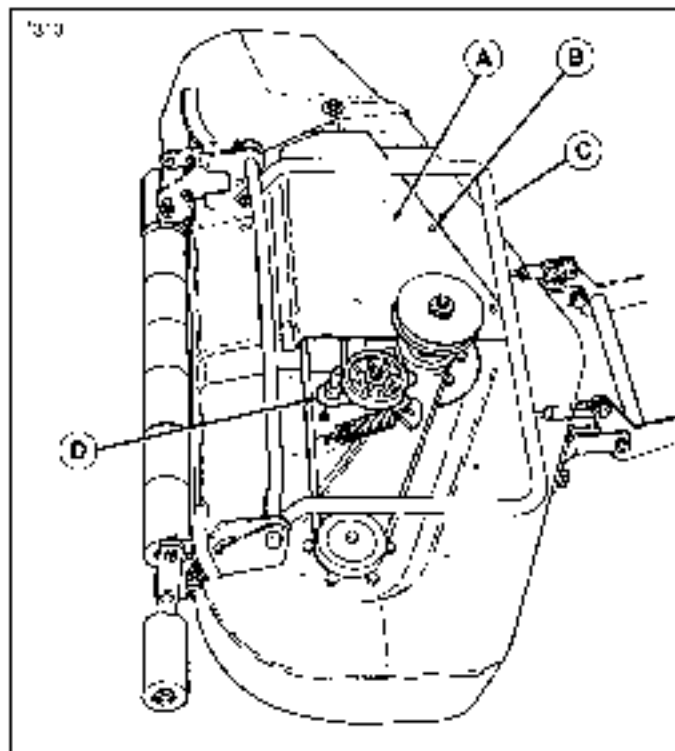

Figure B. Idler Pulley Pivot (48" Mower Shown)

- A. Cover
- B. Taprites
- C. Ball Assembly
- D. Idler Pulley Pivot

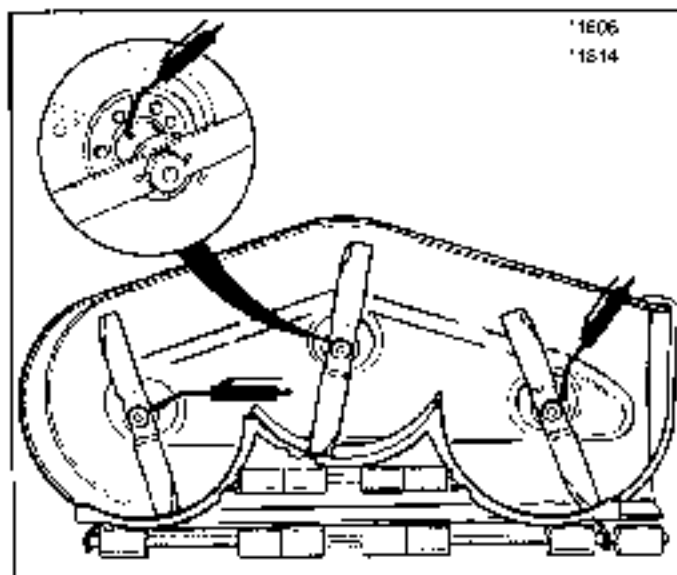

Figure 8A. Mower Arbor

CHECK BEVEL GEAR BOX FLUID

Check the bevel gear box fluid level. Remove the fill plug (A, figure 9) and wipe oil off attached pin. Insert the fill plug loosely in hole (do not screw in). In this position, the fluid should just touch the bottom of the pin. If not, add multipurpose power train oil. Do not overfill.

To drain oil, loosen the capscrews on the rear cover plate.

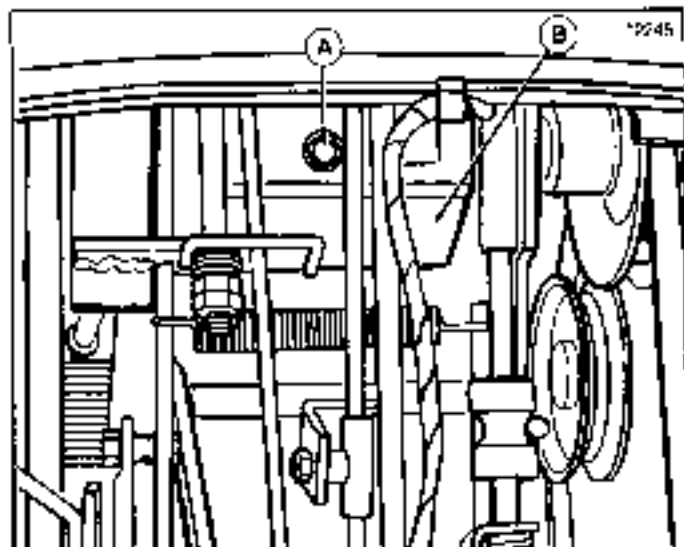

Figure 9. Bevel Gear Box

A. Oil Fill/Check Plug

B. Bevel Gear Box

If the belt has been used before, the rear edge of the idler bracket (A, figure 15) should be in the middle of the green zone shown in figure 15. The distance between idler bracket (A) and stop (C) will be approximately 7/8 inch (22 mm).

If adjustment is required, go to step 13. If adjustment is not required, go to step 14.

13. Push the belt tensioning lever down to release belt tension. Loosen the nut that secures the rear idler pulley (D, figure 15) in the slot. To move the idler bracket (A) forward, move rear idler pulley (D) toward rear. To move the idler bracket (A) toward rear, move the idler pulley (D) forward. Tighten the nut to secure pulley. Pull the belt tensioning lever up and recheck position of idler bracket (A). Readjust if necessary.
14. Operate the tractor with mower engaged for 15 to 30 minutes with a new belt or about two minutes with a used belt. Then, disengage the PTO, stop the engine, remove the key, shift into neutral, set the parking brake. Check position of idler bracket (A, figure 15). If the rear edge of idler bracket is in middle of green zone, the belt adjustment is acceptable. If not, readjust the belt as described in step 13.
15. If a new belt or mower was installed, level the mower as described in the Adjustments section.

NOTE

Check belt adjustment periodically during mowing season. Drive belt must be readjusted when rear edge of idler bracket aligns with rear edge of green zone or goes into the red zone.

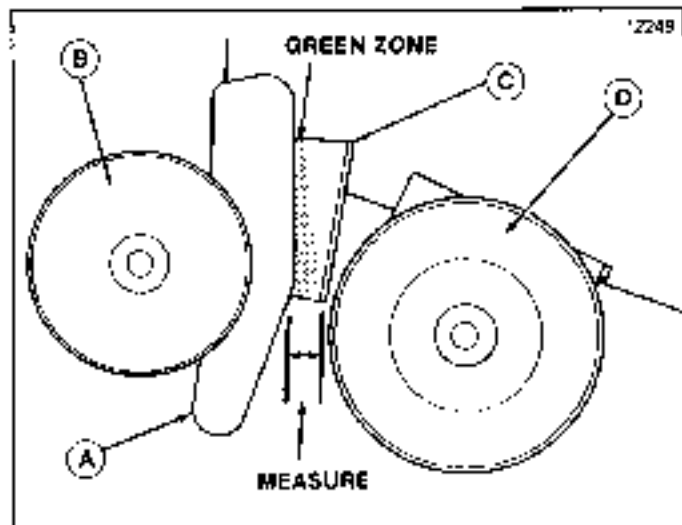

Figure 15. Belt Adjustment

- A. Idler Bracket
- B. Front Idler Pulley
- C. Stop
- D. Rear Idler Pulley

MOWER REMOVAL

**WARNING**

Before leaving operator's position, lower the attachment, shut off engine and remove key, disengage power to attachments, and set parking brake.

**WARNING**

It will be necessary to start the engine to raise or lower the mower. Before starting the engine, always seat yourself in operator's position. Before leaving operator's position, shut off the engine and remove the key.

1. Park the tractor on a flat, hard surface where there is room to remove the mower at the left side of the tractor.
2. Push the belt tensioning lever (C, figure 14) fully down and forward to release mower belt tension.
3. Raise the tractor seat deck and remove the mower drive belt from the mower and tractor pulleys (see figure 14). Close the tractor seat deck.
4. Use the tractor lift lever to raise the mower halfway.
5. Remove the safety clips and pins to detach the mower hitch from the tractor hitch. Remove the right hand side pin first. Reinstall the pins and safety clips in the mower hitch for storage.
6. Lower the mower fully.
7. Remove the spring clip and pin to detach the lift cable from the mower. Reinstall the pin and spring clip in the lift cable for storage.
8. Turn tractor wheels for a sharp right hand turn, and slide the mower out the left side of the tractor.
9. Pull the belt tensioning lever fully back and up out of the way to prevent damaging it when using the tractor without the mower.

SERVICING THE MOWER BLADES



WARNING

Do not handle the blade with bare hands. Do not touch the cutting edge.

Sharpening & Balancing

1. To remove a blade, wedge a wood block between blade and housing to prevent rotation as shown in figure 16. Then, turn capscrew counterclockwise to remove.
2. Use a file to sharpen blade to a fine edge. Remove all nicks and dents on blade edge. If blade is severely damaged it should be replaced.
3. To balance the blade, use a balancing machine or the following procedure. Drive a small nail into the side of a workbench or other vertical surface as shown in figure 17. Lubricate the nail with a drop of oil. Center the blade center hole on the nail. A balanced blade will remain level. File material off heavier end of blade until it is balanced.

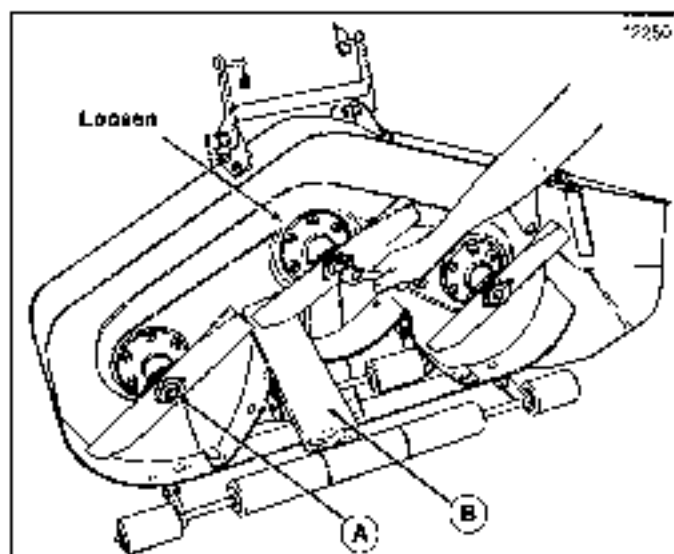

Figure 16.
A. Blade Mounting Capscrew
B. Wooden Block

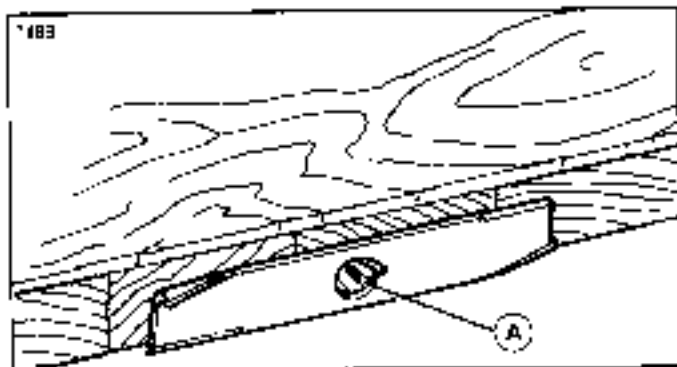

Figure 17.
A. Finishing Nail

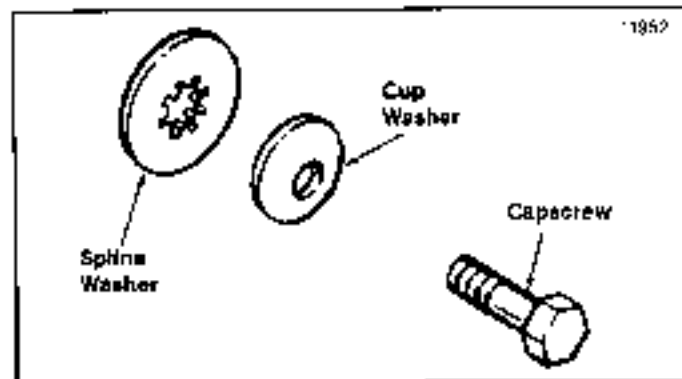

Figure 18. Blade Hardware

Blade Installation

1. Reinstall the blade(s) with the tabs pointing upward. Install the splino washer, cup washer, and cap screw (see figure 18). Be sure the splines on the splino washer are engaged with the shaft splines. Splino washer should be installed with the collar up (inside mower blade hole). Be sure cup washer is installed with the concave side up.
2. To tighten the cap screw, wedge a wood block between blade and housing to prevent blade from turning. Torque the cap screw to 60 to 70 ft. lbs. (82-95 Nm).

Troubleshooting

CONTENT OF SECTION

This section of the manual provides troubleshooting for the more common and easily corrected problems. For other problems, it is recommended that you contact your dealer.



WARNING

Perform maintenance on the tractor or mower only when the engine is stopped and the parking brake engaged. Always remove the ignition key before beginning the maintenance to prevent accidental starting.

Problem	Cause/Remedy
1. Engine will not turnover or start.	<p>A. Transmission lever not in neutral-start position. Shift into neutral.</p> <p>B. PTO lever engaged. Place in disengaged position.</p> <p>C. Out of fuel. Allow engine to cool then refill the fuel tank.</p> <p>D. Engine flooded. Push choke knob in.</p> <p>E. Circuit breaker tripped. Wait one minute for automatic reset. Replace if defective (see your dealer).</p> <p>F. Battery terminals require cleaning. See Normal Care section.</p> <p>G. Battery discharged or dead. Recharge or replace.</p> <p>H. Wiring loose or broken. Visually check wiring & replace broken or frayed wires. Tighten loose connections.</p> <p>I. Solenoid or starter motor faulty. Repair or replace.</p> <p>J. Safety interlock switch or relay faulty. Replace if needed (see your dealer).</p> <p>K. Spark plugs faulty, fouled or incorrectly gapped. Clean and gap or replace. See engine manual.</p> <p>L. Water in fuel. Drain fuel & refill with fresh fuel.</p> <p>M. Old stale gas. Drain fuel & replace with fresh fuel.</p>

Problem	Cause/Remedy
2. Engine starts hard or runs poorly.	<p>A. Fuel mixture too rich. Clean air filter. Check choke adjustment (engine speed control). See engine manual.</p> <p>B. Carburetor adjusted incorrectly. See engine manual.</p> <p>C. Spark plugs faulty, fouled, or incorrectly gapped. Clean and gap or replace. See engine manual.</p>
3. Engine knocks.	<p>A. Low oil level. Check/add oil as required.</p> <p>B. Using wrong grade oil. See engine manual.</p>
4. Excessive oil consumption.	<p>A. Engine running too hot. Clean engine fins, blower screen and air cleaner.</p> <p>B. Using wrong weight oil. See engine manual.</p> <p>C. Too much oil in crankcase. Drain excessive oil.</p> <p>D. Oil Drain valve leaky. Make sure valve petcock is closed (turn clockwise).</p>
5. Engine exhaust is black.	<p>A. Dirty air filter. Clean air filter. See engine manual.</p> <p>B. Check engine speed control adjustment (choke). See engine manual.</p>
6. Engine runs, but tractor will not drive.	<p>A. Transmission control lever in neutral. Shift in forward or reverse.</p> <p>B. Transmission release lever in "push" position. Move into drive position.</p> <p>C. Belt is broken. See "Drive Belt Replacement". (See Adjustments section.)</p> <p>D. Drive belt slips. (See problem and cause below.)</p>
7. Tractor drive belt slips.	<p>A. Clutch is out of adjustment. See your dealer.</p> <p>B. Pulleys or belt greasy or oily. Clean as required.</p> <p>C. Belt stretched or worn. Replace with correct belt.</p>

Troubleshooting

Problem	Cause/Remedy
8. Brake will not hold.	A. Brake is incorrectly adjusted. See Brake Adjustment or Brake Pedal Adjustment.
9. Tractor steers hard.	A. Steering linkage is loose. Check and tighten any loose connections. B. Improper tire inflation. Check and correct. C. Spindle bearings dry. Grease spindles. See Normal Care - Lubrication section.

TRUBLESHOOTING (MOWER)

1. Mower will not raise.	A. Lift arms or lift link not properly attached or damaged. Attach or repair.
2. Mower cut is uneven.	A. Mower not leveled properly. See Mower Leveling. B. Tractor tires not inflated equally or properly. See Normal Care section.
3. Mower cut is rough looking.	A. Engine speed too slow. Set for three-fourths to full speed. B. Ground speed too fast. Use transmission lever to control ground speed. C. Blades dull and require sharpening. See Normal Care section. D. Mower drive belt slipping. Belt oily or worn. Clean or replace belt as necessary. E. Blades not properly fastened to arbors. See Normal Care section.

Problem	Cause/Remedy
4. Engine stalls easily with mower engaged.	<ul style="list-style-type: none"> A. Engine speed too slow. Set for 3/4 to full throttle. B. Ground speed too fast. Use slower ground speed. C. Carburetor not adjusted properly. D. Cutting height set too low when mowing tall grass. Cut tall grass at maximum cutting height during first pass. E. Discharge chute jamming with cut grass. Cut grass with discharge pointing toward previously cut area.
5. Excessive mower vibration.	<ul style="list-style-type: none"> A. Mower blades, arbors, or pulleys are bent. Check and replace as necessary. B. Mower blades are out of balance. Remove, sharpen and balance blades (see Normal Care section). C. Belt installed incorrectly. See "Mower Belt Replacement".
6. Excessive belt breakage.	<ul style="list-style-type: none"> A. Bent or rough pulleys. Repair or replace. B. Using incorrect belt. See your dealer.
7. Mower drive belt slips or falls	<ul style="list-style-type: none"> A. Idler pulley spring broken or not properly attached. See "Mower Belt Replacement." B. Mower drive belt broken. Replace. See "Mower Belt Replacement".

DRIVE BELT REPLACEMENT

1. Tie the clutch-brake pedal down in the disengaged position.
2. Raise the tractor seat deck.
3. Remove the capscrew (C, figure 20) and remove the belt guard assembly (B).
4. Remove the two capscrews (D) and the tapitite screw (E) to remove the fan guard assembly.
5. Remove the old belt and install the new one. Make sure the belt is in all pulley grooves and is not twisted.
6. Reinstall the fan guard with the capscrews (D) and the tapitite screw (E).
7. Release the clutch-brake pedal and check to be sure belt is still seated in all pulleys.
8. Reinstall the belt guard (B) so the bracket on the back side almost touches the pulley hub. Hold the guard in place and tighten the capscrew (B).
9. Check and adjust the tractor clutch according to the instructions in the Adjustment section.
10. Lower and latch the seat deck when finished.

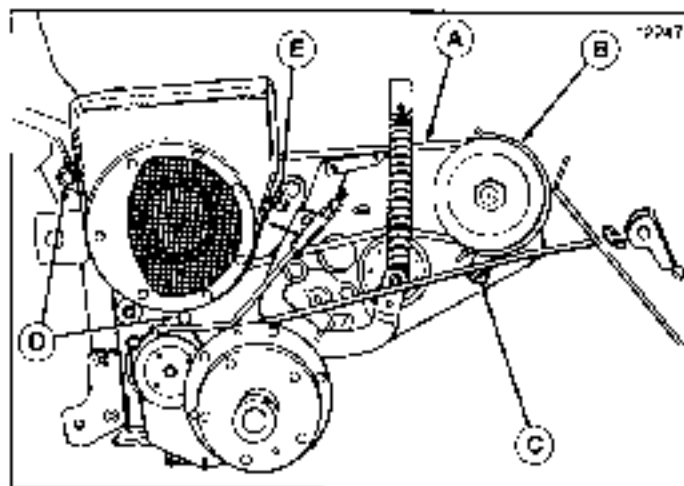
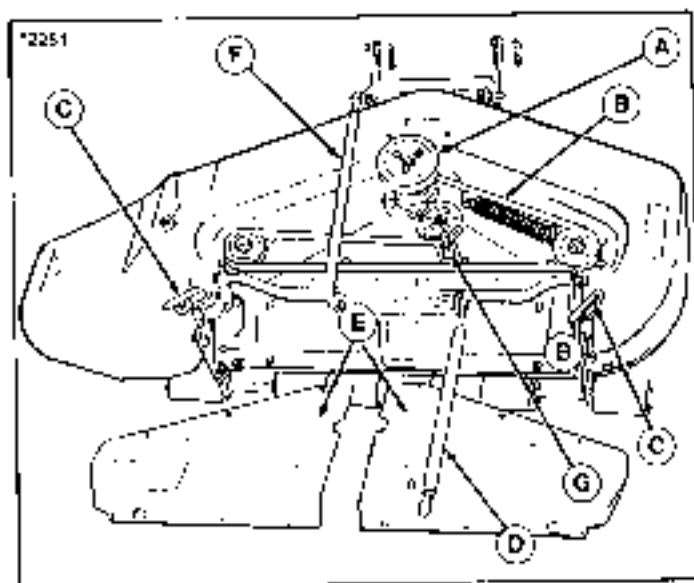

Figure 20. Drive Belt Replacement

- A. Belt
- B. Belt Guard
- C. Capscrew
- D. Fan Guard Capscrews
- E. Tapitite Screw

MOWER BELT REPLACEMENT

1. Remove mower from tractor as instructed in "Mower Removal."
2. Remove the self-tapping screws from the covers. The 42 inch mower has 10 screws. The 48 inch mower has 14 screws.
3. **For the 42 inch mower,** remove the cotter pin and pull back the right-hand levelling bar (D). Lift the right-hand belt cover over the lift anchor. Remove the left-hand cover.
4. **For the 48 inch mower,** lift the bar assembly slightly to provide access for cover removal. Remove the left-hand belt cover first. Then spring the inner edge of the right-hand belt cover up over the lift anchor (G) and slide it out from under the levelling rod.
5. Clean the interior of the mower belt housing.
6. The idler pulley arm pivots at the lift anchor. Make sure the arm pivots freely. Lubricate the idler pivot fitting as necessary with a drop of oil or a shot of grease (if equipped with grease fitting). Do not get oil or grease on the mower grill.
7. Unhook the idler spring (B) from the idler (A). Remove the old belt from the pulleys. Install the new belt and reattach idler spring (B).
8. Reinstall the belt covers and connect the levelling bars. Be sure to spread cotter pin legs fully. When installing the right-hand belt cover, be sure the belt is positioned in the belt guide which is located on bottom of belt cover.

**Figure 21. Mower Drive Belt - 42 inch Mower Shown**

- A. Idler Pulley
- B. Mower Belt
- C. Height Adjusting Lever
- D. Levelling Bar, RH
- E. Belt Covers
- F. Levelling Bar, LH
- G. Lift Anchor

SEAT ADJUSTMENT

1. Lift up the seat as shown in figure 23
2. Loosen the four capscrews under the seat and slide the seat forward or back. Tighten the capscrews firmly.
3. The springs (B) can be moved to different holes in the deck for maximum riding comfort. A lighter person will want to move the springs more forward. To change position, lift the springs and move to desired holes.

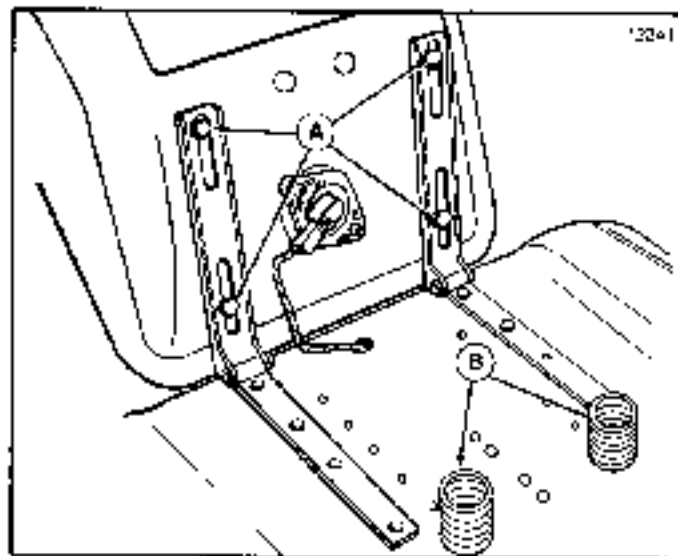

Figure 23. Seat Adjustment

A. Capscrews

B. Springs

PTO CLUTCH ADJUSTMENT

The PTO clutch is properly adjusted when the clutch pulley (C, Figure 24) moves away from clutch cone (D) 1/16 inch (1.5 mm) when clutch is disengaged. To adjust, proceed as follows.

1. Loosen the rear nut (B).
2. Turn the front nut slightly clockwise to increase pulley travel or counterclockwise to decrease pulley travel.
3. Tighten the rear nut against the front nut and repeat the check.
4. Adjust locknut (E) so there is 1/8" (3 mm) between locknut (E) and pivot arm when clutch is disengaged.

MOWER BELT STOPPING TIME

Brake pads installed on the PTO clutch will stop the mower drive belt and blades within several seconds.

If the PTO clutch is serviced or adjusted, check the mower belt stopping time by observing the belt when the PTO is disengaged. If belt does not stop within five seconds, PTO clutch must be adjusted or clutch brake requires service. See "PTO Clutch Adjustment".

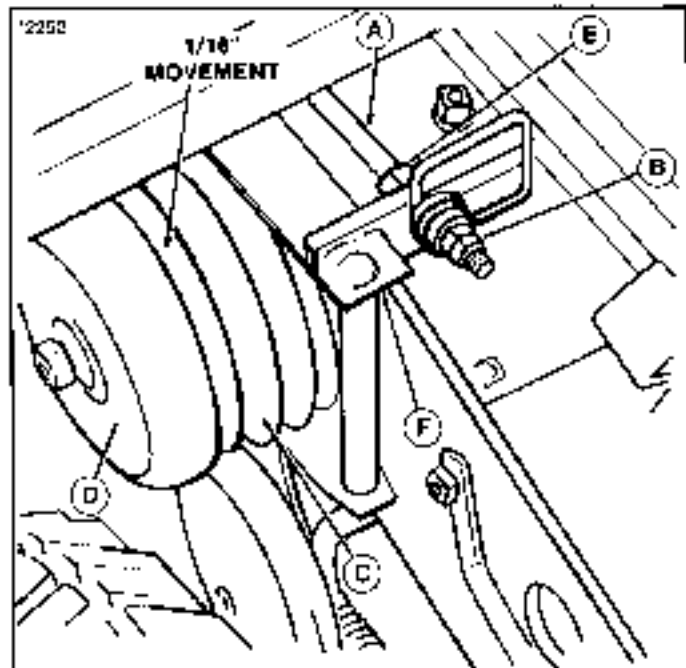

Figure 24. PTO Clutch Adjustment

- A. PTO Clutch Rod
- B. Jam Nut
- C. Clutch Pulley
- D. Clutch Cone
- E. Locknut
- F. Pivot Arm

PARKING BRAKE ADJUSTMENT

To adjust parking brake, loosen the jam nut (E, figure 25) at parking brake rod end. Rotate the parking brake handle (B) clockwise until it is tight and pulled up against fender as shown. Operate the brake handle to see if it is too loose or too tight. It should be tight against fender when set but not too tight to operate. When proper adjustment is made, tighten the jam nut.

It will be easier to apply the parking brake when the clutch/brake pedal is pushed down all the way.

CLUTCH/BRAKE ADJUSTMENT

1. To adjust the foot brake, engage the parking brake. Adjust jam nuts (H, figure 25) on end of foot brake rod to provide 1/2 inch (12.7 mm) spring length between washers. Depress the pedal to engage the brake. The drive belt should be slack and free of idler pulley. If not, check clutch adjustment (step 2). Test operate the tractor. If brake does not stop the tractor, see your dealer.
2. To adjust tractor clutch, adjust jam nuts (J) on clutch rod so there is 1/2 inch (12.7 mm) spring length between washers with clutch-brake pedal in up position.

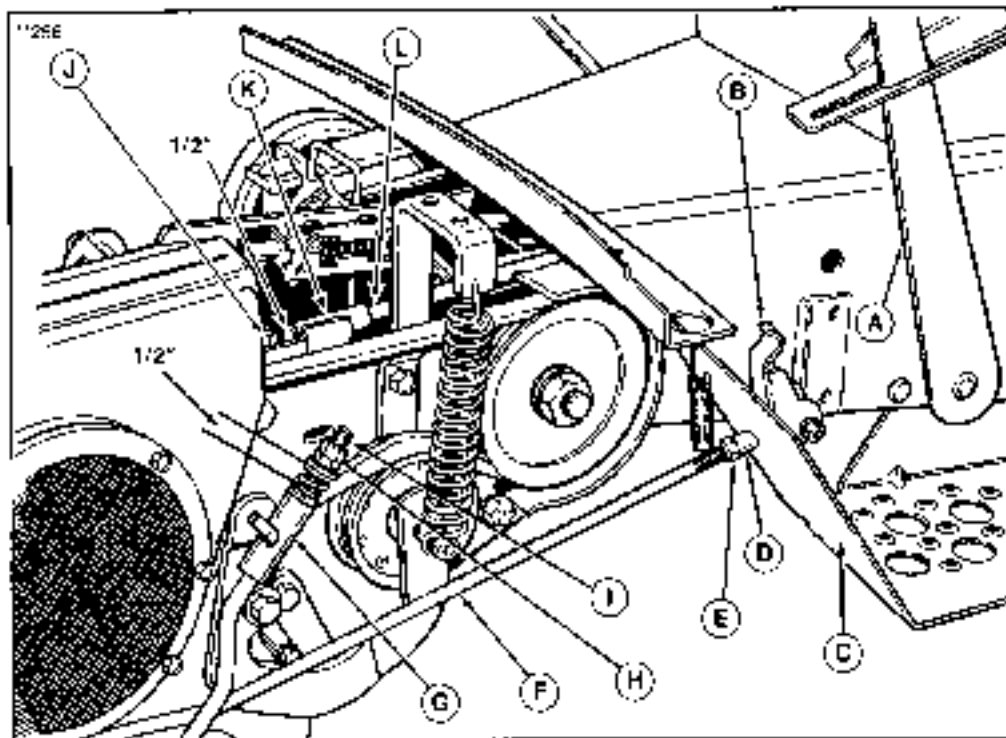

Figure 25. Brake & Clutch Adjustment

A. Hydrostatic Control Lever

B. Parking Brake Handle

C. Fender

D. Parking Brake Rod End

E. Jam Nut

F. Parking Brake Rod

G. Foot Brake Rod Guide

H. Jam Nuts

I. Foot Brake Rod

J. Jam Nuts

K. Clutch Rod Guide

L. Clutch Rod

NEUTRAL ADJUSTMENT

If the tractor creeps forward or back when the hydrostatic control lever is in neutral, adjust as follows:

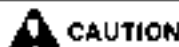

CAUTION

Always stop engine before leaving operator's position.
Do not perform adjustment with engine running.

1. Park tractor on level ground, make sure hydrostatic control lever is firmly seated in the neutral notch of quadrant, stop engine and set parking brake.
2. Raise the seat deck and check if the pump control arm roller (E, figure 2B) is exactly centered with the centering mark (D). If not, loosen bolt (C) and move the control cam (B) until centering mark (D) is centered on roller (E). Tighten the bolt (C).
3. Lower the seat deck, get in operator's seat, start engine and release parking brake. If tractor still creeps with hydrostatic control lever in neutral, note which direction it creeps and proceed with next steps.
4. Stop the engine, set parking brake, and raise seat deck. Loosen the jam nut (H) on end of cam pivot shaft (G). If tractor creep had been in reverse, turn adjusting nut (I) 1/8 to 1/4 turn clockwise when viewed from right side of tractor. If tractor creep had been forward, turn nut 1/8 to 1/4 turn counterclockwise. Lock jam nut, lower seat

deck, get in operator's seat, start engine, and release parking brake. If tractor still creeps, repeat step "4", turning nut (I) a little at a time until no creep occurs.

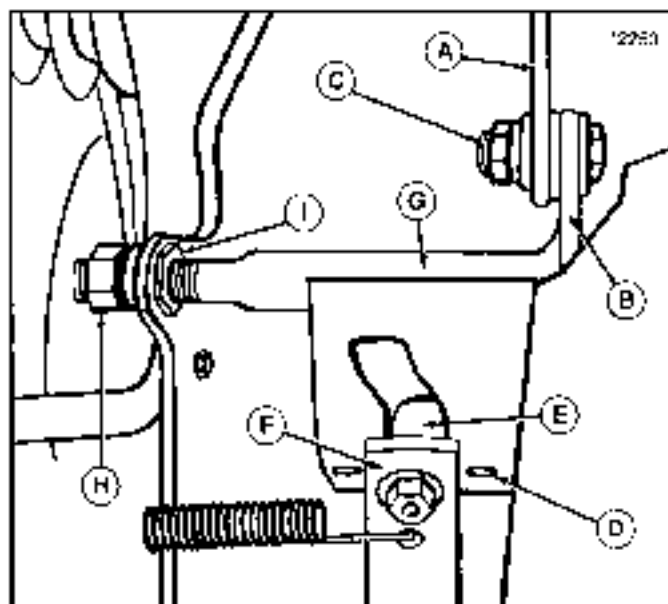

Figure 2B. Hydrostatic Neutral Adjustment

- | | |
|----------------------------|---------------------|
| A. Control Strap | F. Pump Control Arm |
| B. Control Cam Assy. | G. Cam Pivot Shaft |
| C. Bolt | H. Jam Nut |
| D. Centering Mark | I. Adjusting Nut |
| E. Pump Control Arm Roller | |

Common Replacement Parts

Listed below are part numbers for the more common replacement parts. Use the order form at the back of the manual to order a complete, illustrated parts manual. Only genuine replacement parts will assure optimum performance and safety. Do not attempt repairs or maintenance unless proper procedures and safety precautions are followed. For assistance in any area, see your dealer.

REPLACEMENT PARTS

QTY. PER UNIT	DESCRIPTION	PART NUMBER
1	Clavis Pin - Lift Cable	153058
1	Collar Pin - Lift Cable	1918447
1	Spring Clip - Lift Cable	1918198
1	Transmission Belt	1650502
1	2 Keys with Ring	122203
2	Headlight Bulb	1677371
3	Blade - 42" Mower	1679917
3	Blade - 48" Mower	1679916
1	Belt - 42" Mower, Arbor Drive	1656980
1	Belt - 48" Mower, Arbor Drive	1657044
1	Belt - 42" Mower, Mower PTO Drive	1666801
1	Belt - 48" Mower, Mower PTO Drive	108508
2	Mower Hitch Pins	156306
2	Clips for Mower Hitch Pins	176012
1	Collar Pin for Leveling Mechanism	1918452
2	Pins, Leveling - 48" Mower only	1980116
1	Pivot Pin, Leveling - 42" Mower only	1651518
1	Battery	1885058

DESCRIPTION	PART NUMBER
Simplicity Engine Oil:	
- SAE9W-30 Cold Weather Engine Oil	* 1685876
- SAE 30W - 32° and above	* 1685688
Multi-Purpose Hydraulic/ Transmission Oil	* 1685516

* Case of 12 qts. See your dealer to buy individual quarts.

Gross Gun Kit	1685510
8 Oz. Tube - for above	103077
Touch-Up Paint	
Deep Orange Spray Paint, 13 Oz. Can	1685611
Deep Orange Paint, 1 Qt.	1685612
Deep Orange, 1/2 Oz. Touch-up Dauber	1685615
Gloss Black Spray Paint, 13 Oz. Can	1685639
Gloss Black Paint, 1 Qt.	1685641
Pneumatic Tire Seal - Stops Leaks. Available in following amounts:	
11 Oz. Tube	1685523
Case of 24-11 Oz. Tubes	1685825
12 Pac - 11 Oz. Tubes	1685537
Hourmeter Kit	1685535
Designer Seat Cover	1685841

Specifications

ENGINE:

Make:	Kohler Command OHV
Model:	CH 18 5
Horsepower:	18 HP @3600 RPM, Engine Manufacturer's Rating
Bore:	3.03 in. (77mm)
Stroke:	2.64 in. (67mm)
Displacement:	38 cu. in. (624cc)
Crankshaft:	Horizontal, Cast Aluminum
Construction:	Cast Iron Cylinder Liners Cast Aluminum Crankcase
Electrical System	15 Amp Flywheel Alternator - Solid State Regulator - Rectifier 12 Volt - 296 Cold Cranking Amps 60 Minute Reserve Key Ignition Switch Ammeter on Instrument Panel
Ignition	Electronic
Governor	Type: Internal Fly-Weight w/External Adjustment Range: 3600 ± 75 RPM Wide Open Throttle, No Load
Air Cleaner	Type: Replaceable Paper w/Oiled Foam Pre-Chamber
Crankcase	Breather: Ventilated through Air Cleaner Lubrication: Pressurized Spray System Oil Capacity: 2 Qt. (1.9L)

Fuel Tank	Material: Non-Corrosive Polyethylene Fuel Level Gauge Built into Filler Cap Capacity: 3 Gallons (11.4 L)
Muffler	Quiet Compact, Low Back Pressure

TRANSMISSION

Type	Hydrostatic Pump and Motor Air Cooled by Oil Fan Variable Displacement Axial Piston Fixed Displacement Reversible Axial Piston Type, Simplicity Multipurpose Hydraulic/ Transmission Oil Reservoir, Final Drive Gear Case, 3 Qt. (2.8 L) Cap. Filter Cartridge w/25 Micro Rating, Full Flow, w/o Anti-Drain Back
Pump Motor Hydraulic Fluid	Spring Dampened Single Lever Neutral Detent with Safety Start Switch Free Wheeling Valve and Latch for Manual Tractor Movement
Control	Continuously Variable, Forward and Reverse, without Clutching or Stalling Forward: 0 - 7 MPH (0 - 11.3 km/h) Reverse: 0 - 4 MPH (0 - 6.4 km/h)
Speed Range @ 3600 RPM	Hardened Spur Gears Rolling Contact Bearings Planetary Spur Gear, Controlled Traction Type
Final Drive	
Differential	

CHASSIS:

Frame	Channel Electrically Welded, Heavy Gauge Steel Power Take-Off Points: Front, Center, Rear Engine Mounting: Above Front Axle Rivet Point Location: At Front Axle
Rear Wheels	Pneumatic Inflation Pressure: 8-8 psi (41-66 kPa) Tire Size: 21" x 10.50-12 Turf Type
Front Wheels	Pneumatic Inflation Pressure: 12-15 psi (82-103 kPa) Tire Size: 16" x 5.50-8
Accessibility Seat	Hood Taps Forward, Seat Deck Taps Rearward Type: Molded Foam, High Back Cover: Black Vinyl Adjustable Spring Suspension
Turning Radius	Inside Rear Tire: 32 in. (81 cm)

CONTROLS:

Steering	Full Circle Steering Wheel System: 4:14 to 1 Ratio Gear and Sector
Clutch-Brake Pedal	Location: Right Front Clutch: Soft Action, V-Belt Clutch Brake: External Band Type Parking Brake Lock: Standard Equipment
Location	Hydraulic Lift Lever: Left Side Power Take-Off Clutch Lever: Left Side Transmission Control Lever: Right Side Ignition Key Switch, on dash panel Light Switch, on dash panel Throttle Lever, on dash panel Choke Control, on dash panel Ammeter, on dash panel Parking Brake Lock: Lower Right of Seat

DIMENSIONS:

Overall Length	70 in. (178 cm)
Overall Width	26.8 in. (68 cm)
Height	To Top of Dashboard: 25.7 in. (65 cm) To Top of Steering Wheel: 39.7 in. (101 cm)
Wheel Base	50.7 in. (127 cm)
Weight (approx.)	Net: 685 lbs. Shipping: 808 Lbs. w/48" Mower: 858 Lbs.

MOWER:

Effective Cutting Width	48" Mower - 46 in. (122 cm)
Overall Width With Deflector	48" Mower - 62 in. (156 cm)
Weight (approx.)	48" Mower - 135 Lbs. Net; 150 Lbs. Shipping
Variable Cutting Height	1.62" - 3.12" (4.1 - 7.9 cm)
Blade Arrangement	Three Staggered Blades
Mower Drive Spindle Bearings	V-Belt Iron Tractor PTO Pulley Lubricated and Sealed Ball Bearings - Lube Fitting Provided

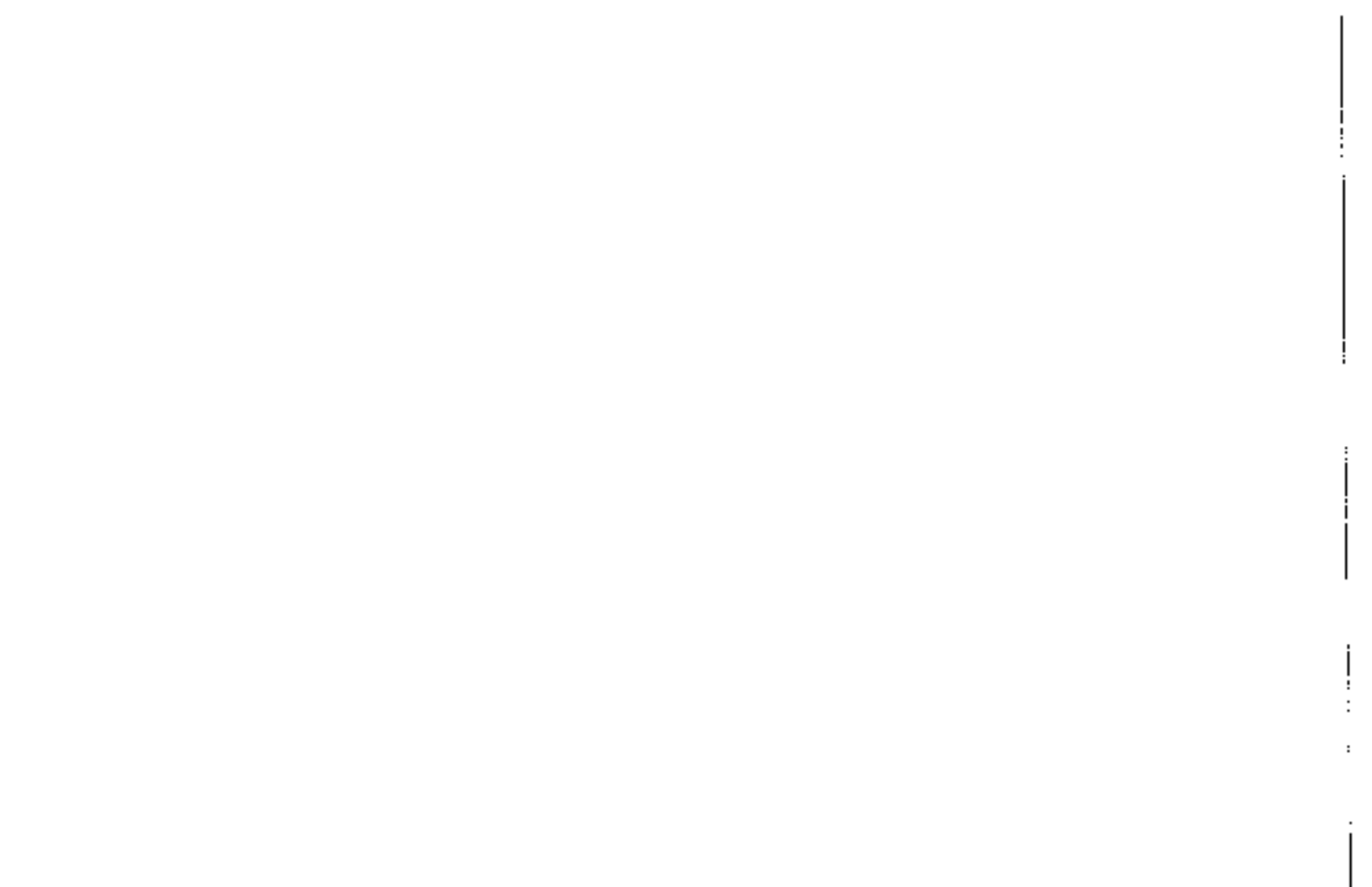



**DEUTZ
ALLIS**

LAWN & GARDEN EQUIPMENT

500 N. Spring St., P.O. Box 997 Port Washington, WI USA 53074-0997

FORM 138890
PRINTED IN U.S.A.
1990 LW32